

Experimental Modal Analysis, Structural Modifications and FEM Analysis on a Desktop Computer

Kenneth A. Ramsey, Structural Measurement Systems, San Jose, California

This article discusses two popular parts of modern day structural dynamics technology; the experimental portion which is referred to as experimental modal analysis or modal testing, and the analytical portion, which is referred to as Finite Element Analysis (FEA) or Finite Element Modeling (FEM). It discusses how experimental and analytical methods are used to solve noise and vibration problems and the importance of using modal parameters to link testing and analysis. Finally, it shows how structural modification techniques are used as a complement to both methods and how all of the tools may be combined on an inexpensive desktop computer. The article concludes with an example showing how experimental modal analysis, structural dynamics modification and finite element analysis were used to analyze the dynamic properties of a test structure.

Most noise, vibration or failure problems in mechanical structures and systems are caused by excessive dynamic behavior. This behavior results from complex interactions between applied forces and the mass-elastic properties of the structure. Currently, many companies are actively using Finite Element Modeling (FEM) techniques for structural dynamic analysis. In recent years, however, the implementation of the Fast Fourier Transform (FFT) in low cost computer-based signal analyzers has provided the environmental testing laboratory with a fast and more powerful tool for acquisition and analysis of vibration data. As a result, *more and more companies are beginning to use dynamic testing to complement their FEM structural analysis activities.* It is this interaction between the experimentalist and the analytical engineer that is so important. Both are able to communicate and reinforce one another to solve troublesome noise and vibration problems that are certain to arise in the life cycle of a product.

It is the intent of this article to report on how virtually any design or testing engineer can take advantage of recent advances in computer technology and software developments which allow him to easily use a system capable of offering advanced experimental methods as well as analytical methods in the same basic framework.

Before doing so however, it is worthwhile to review some historical facts about FEM and experimental modal analysis, and the associated problems that still confront most of us today.

A Historical Perspective

In the early days of the U.S. space program, design engineers recognized the importance of formulating mathematical dynamic models of structures so that they could

use them to predict their dynamic performance in flight. Obviously, it was necessary to predict dynamic performance as accurately as possible prior to launch because there simply was no second chance. Classical rigid body analysis was inadequate for many dynamics problems. Similarly, elastic body analysis methods, which require solutions to a set of partial differential equations, were found to be far too restrictive for describing the dynamics of complex structures. Additionally, partial differential equations do not readily lend themselves to solution with computerized numerical methods.

The requirement for a more generalized method for modeling the dynamics of large, complex structures with non-homogeneous physical properties thus brought the development and use of Finite Element Modeling (FEM) methods.

In order to use FEM models with confidence, it was found to be necessary to confirm the accuracy of the model by comparing the modal parameters (frequency, damping and mode shapes) predicted by the model with the modal parameters identified by actually testing the structures. In fact, most of the advancements in experimental modal testing came about from the demand to verify the accuracy of FEM models.

In the early 1960's, when FEM methods were beginning to be used extensively, they proved to be so expensive that only the largest organizations were able to use FEM effectively. This large cost was due primarily to the fact that a very large computer was required in order to handle the models. Experimental modal analysis suffered from much the same problem since we did not have the modern Fast Fourier Transform (FFT) that we do today.

Over the years, many excellent FEM codes have been developed. These codes are able to run effectively on a wide range of computers in the mainframe and super-minicomputer (VAX, Prime, Harris, etc.) classification. As the prices of these machines have dropped, more and more companies have been able to take advantage of the considerable benefits available to FEM users. However, FEM techniques are not without problems. Some of the most common advantages and disadvantages of finite element modeling, from a dynamics viewpoint, are summarized in Table 1.

Most finite element computer programs are very large in size and require larger computers with large memories in which to operate. Hence, it is not unusual for companies to spend thousands of dollars to develop a single finite element model. To obtain the required accuracy, models containing several thousand degrees-of-freedom are not uncommon. Models of this size require many man-hours of effort to develop, debug and operate.

Another disadvantage of finite element modeling is that the dynamic response of the model can differ substantially from

that of the actual structure. This can occur because of errors in entering model parameters and when the finite elements do not approximate the real world situation well enough. Many times the model will turn out to be much stiffer than the actual structure. This can be due to the use of an inadequate number of elements or unrealistic boundary conditions between elements.

Both of these disadvantages point to a need for dynamic testing of the structure in order to confirm the validity of a finite element model.

Dynamic Testing

Certainly, one of the most important areas of structural dynamics testing is that of *experimental modal analysis*. Simply stated, modal analysis is the process of characterizing the dynamic properties of an elastic structure by identifying its modes of vibration. That is, each mode has a specific natural frequency and damping factor which can be identified from practically any point on the structure. In addition, it has a characteristic "mode shape" which defines the resonance spatially over the entire structure.

Once the dynamic properties of an elastic structure have been characterized, the behavior of the structure in its operating environment can be predicted and, therefore, controlled and optimized.

In general, modal analysis is valuable for the following reasons:

Table 1. Advantages and disadvantages of finite element analysis.

Advantages

- ❑ The model can be "built and used before any prototype hardware is available.
- ❑ The model can predict a structure's behavior under real world dynamic operating conditions.
- ❑ An engineer can analytically modify the structure (via the FEM model) much cheaper, faster and easier than he can change actual hardware

Disadvantages

- ❑ FEM models can be very difficult and expensive to "build."
- ❑ Modeling is generally done by a skilled dynamicist because of the complexities of the available FEM codes.
- ❑ A model can be, and indeed is often inaccurate.
- ❑ Models can be expensive to run, depending on the size of the model. They may also require a large computer for operation.
- ❑ Many implementations cause a user to wait hours before either plotted or printed results are available.

Verifying Analytical Models. Modal analysis is a useful tool for verifying and helping improve the accuracy of analytical FEM models of a structure. The equations of motion solved by a finite element analysis are based on an idealized model and are used to predict and simulate dynamic performance of the structure. They also allow the designer to

examine the effects of changes in the mass, stiffness and damping properties of the structure in greater detail. For anything except the simplest structures, modeling is a formidable task. Experimental measurements on the actual hardware result in a physical check of the accuracy of the mathematical model. If the model predicts the same modes of vibration that are actually measured, it is reasonable to extend the use of the model for simulation, thus reducing the expense of building hardware and testing each different configuration. This type of modeling plays a key role in the design and testing of aerospace vehicles and automobiles, to name only two.

Troubleshooting. Modal analysis is instrumental in "troubleshooting" noise, vibration and failure problems. By understanding how a structure deforms at each of its resonant frequencies, judgments can be made as to what the source of the disturbance is, what its propagation path is, and how it is radiated into the environment. Modal analysis is also used to locate structural weak points. It provides added insight into the most effective product design for avoiding failure. This often eliminates the tedious trial and error procedures that arise from trying to apply inappropriate static analysis techniques to dynamics problems.

Evaluation of Fixes. Modal analysis can be used to quickly and accurately evaluate "fixes" which are made to structures in order to solve certain noise or vibration problems.

Formulation of Dynamic Models. Modal analysis can also be used to form the basis of a dynamic model for parts or structures that are simply too difficult or time consuming to model analytically.

Thus far, we have examined some of the advantages and disadvantages of experimental modal analysis and finite element analysis. However, it is also important for us to recognize how engineers use each of these tools in actually solving noise and vibration problems, and to understand the need for finding ways of combining the benefits of both testing and analysis.

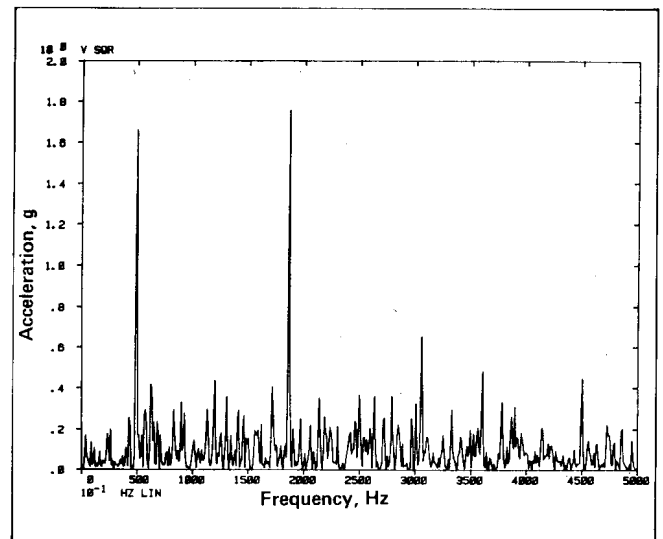

Figure 1. Vibration spectrum of an operating structure.

Experimentally Troubleshooting Noise and Vibration Problems

In addition to verifying analytical models, dynamic testing is also being used today to solve noise and vibration problems which occur in prototype designs or in operational hardware. In those cases where the structure can be effectively tested, the following series of steps are typically followed.'

Step 1 - Characterizing the Problem. The first step in solving any noise or vibration problem is to measure some type of operational data from the structure which characterizes the problem. Typically, so-called order ratio, order tracking or power spectrum measurements, such as that shown in Figure 1, are made on a structure. They indicate which frequencies are dominant, and hence are possible contributors to the problem.

High levels of response (or peaks) in these measurements are due to one or both of the following causes:

- The response is simply a *forced vibration*, due to a large amount of excitation being applied to the structure at one or more frequencies. (These forces often occur in rotating machinery, and are caused, for example, by rotational unbalances, blade passage, gear meshing, etc.)
- The structure has a *resonance*, or natural mode of vibration, which is being excited by some (perhaps small) amount of excitation force. At its resonant frequencies, a structure is easily excited into vibration, or large amplitude response.

Step 2 - Identify Structural Resonances. The second step is to determine which of the two possible causes mentioned above is contributing to the problem. This is done by measuring several so-called frequency response functions from the structure to see if it has any resonances near the problem frequencies. These two-channel measurements (which are formed as the ratio of a response motion divided by an excitation force) will isolate the dynamic properties of the structure from the properties of the excitation force.

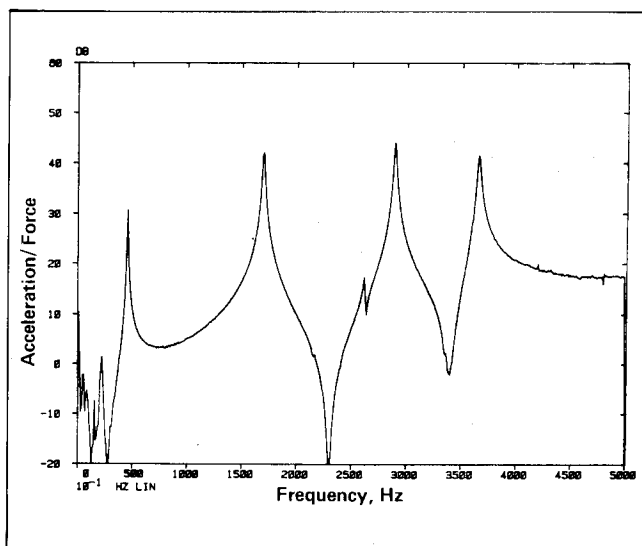

Figure 2. Frequency response measurement to identify structural resonances.

Frequency response measurements, such as that shown in Figure 2, will contain peaks which indicate the presence of structural resonances. A structure is "dynamically weak" and can be easily excited at or near the frequency of a resonance peak.

At this point, if it is determined from preliminary measurements that structural resonances are contributing to the problem, then a more extensive set of measurements should be made to better understand these resonances.

Step 3 - Perform a Modal Analysis. This step is normally carried out to obtain the mode shape (or spatial description of amplitudes) of each structural resonance of interest. A series of frequency response measurements is typically made between several excitation points and a single response point, or alternatively between a single excitation point and several response points. The modal frequencies, damping, and mode shapes are identified by performing further computation (curve fitting) on this set of measurements.

Most modern modal analysis systems have a built-in capability for displaying the mode shapes in animation. This animated picture approximates the predominant vibratory motion of the structure at each resonant frequency, and often provides further insight into the problem.

At this point, an engineer must decide whether the excitation source can be reduced or eliminated, or whether the dynamics of the structure must be altered to control the problem. Many times, it is simply not possible to reduce the level of excitation or alter its frequency content. Therefore the problem must be solved by altering the dynamics of the structure.

Step 4 - Modify the Structure. The final step then, assuming that the structure must be altered, is to choose one of the following techniques:

- Add damping to the structure to attenuate the amplitude of the troublesome resonance (Figure 3).
- Shift a resonance to a higher frequency to avoid the excitation. This can be done by decreasing the mass and/or increasing the stiffness of the structure in a manner that affects the mode of interest (Figure 4).
- Shift a resonance to a lower frequency to avoid the excitation. This can be done by increasing the mass and/or decreasing the stiffness of the structure as required (Figure 5).

It is this final process of altering the mass, stiffness, or damping properties of the structure that is so crucial to the solution of the problem. This can often be a lengthy trial and error process, involving testing and re-testing, since the complex effects of most structural modifications are simply not obvious. Normally, an engineer has to rely solely on his engineering judgment and experience to select a location and amount of mass, stiffness or damping modification. Unfortunately, many times the change is of little value and more changes are required. Hence, it is virtually impossible to predict how much time and money may be required to find satisfactory solutions to noise or vibration problems.

Structural Modifications

"What if" investigations can also be conducted using a mathematical model to determine how changes in the mass, stiffness or damping of the structure will affect its dynamic

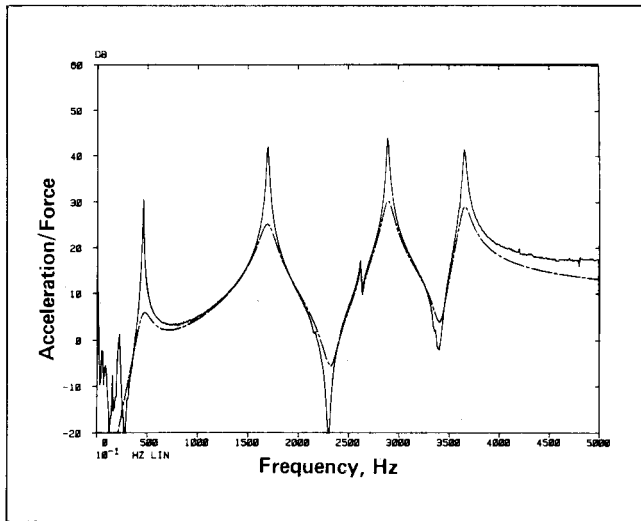

Figure 3. The effect of adding damping to reduce the dynamic response of a structure at resonance.

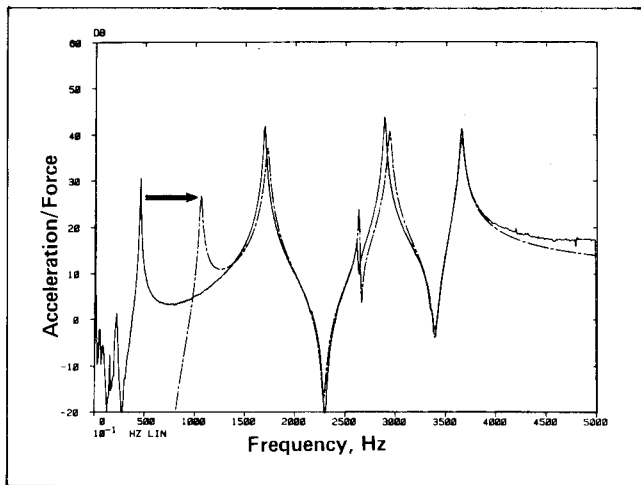

Figure 4. Reduction of objectionable structural response by shifting a problem mode to a higher frequency.

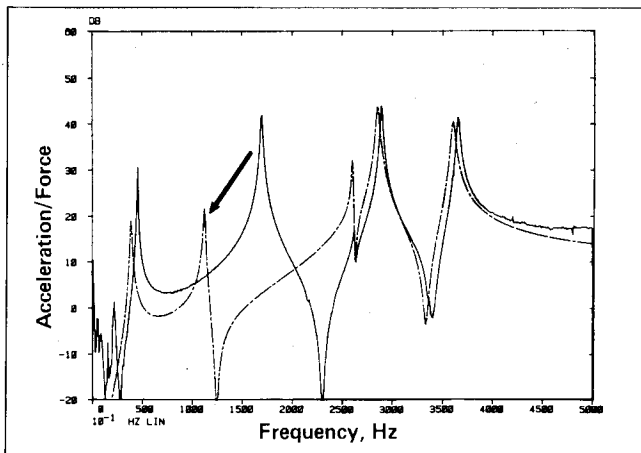

Figure 5. Reduction of objectionable structural response by shifting a problem mode to a lower frequency.

characteristics (i.e. its modes of vibration). Using a finite element model, these types of investigations can be made before the first prototype structure is even built. This way, any deficiencies in the design can be spotted early in the design cycle where changes are less costly than in the later stages. This capability is perhaps the single most important advantage of finite element modeling.

Analytically Modeling Structures with FEA

Just as with the experimentalist, the analyst also has the problem of how to intelligently modify the properties of the structure in order to correctly affect the problem of interest.

Although the analyst has no actual hardware and thus cannot test and re-test, he must do an analogous task with the FEA model. That is, he may potentially have to run and re-run his finite element model in order to investigate the effects of various potential design modifications.

Depending upon the type of FEM code and the computer on which it runs, this repeated "trial and error" approach can prove to be very expensive. Many users report that it is not uncommon for them to spend anywhere from \$500 to \$2,000 to run a dynamic solution to a problem with 2000 degrees-of-freedom, depending of course, on a number of factors. In addition, many users also must wait anywhere from a few hours to a day or so in order to receive hard copy output of the results.

Nevertheless, the point is that neither the experimentalist nor the FEM user can afford the time or the cost associated with a "trial and error" approach to solving dynamics problems.

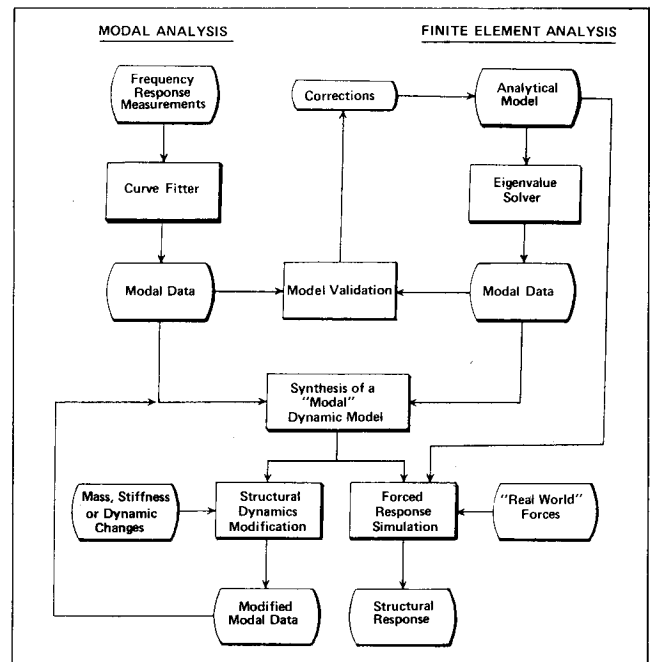

Figure 6. Combined testing and analysis techniques.

All of the above mentioned problems point to an obvious need. That is, to be able to inexpensively use experimental modal analysis and finite element analysis together in a cohesive way such that an engineer can draw on the particular strengths of each technique.

Combined Testing and Analysis

Having reviewed thus far the salient features of both FEM analysis and modal testing, it is clear that both approaches can and should be used in a combined manner to more fully characterize structural dynamics problems. *It is the author's opinion that the use of a structural modification technique provides the key to effectively using testing and analysis to solve noise and vibration problems.*

Figure 6 shows how modal testing and finite element modeling can be combined to solve noise and vibration problems. Notice that the experimentalist begins with a set of frequency response measurements (which he can make with many different brands of FFT analyzers). This fundamental data must then be processed in order to analytically estimate the modal parameters. Although some FFT analyzers contain the appropriate "parameter estimation" algorithms directly, the more general case is for these calculations to be done in an external processor such as a desktop computer. The end result of this analysis is a set of modal data (frequencies, damping and mode shapes) for the structure under test.

In a similar manner, the analytical engineer builds a mathematical model of the structure and then goes through a mathematical process called eigenvalue extraction which yields the modal parameters for the model.

As can be seen, *modal data is the most powerful common link via which analytical and experimental results can be combined.* Once the user has the modal data he can easily assess the accuracy of both of the models. More importantly, this comparison of data can highlight problems and possible errors in either the experimental or analytically-based model. With this information, it is a much simpler task to go back and correct the original FEA model or perhaps even re-measure portions of the structure which may not have yielded a consistent set of data as suggested by the FEA results.

Once the user has a consistent set of modal data, it can be used to synthesize a *modal dynamic model* of the structure. A modal dynamic model is one which is based exclusively on modal parameters. Nevertheless, it is a complete model and totally describes the dynamics of the structure over the specific frequency range for which there is modal data.

The major advantage of a modal model is that it is condensed. Recall that in a finite element model, the size is a function of the number of degrees-of-freedom n . So, if the model has 1000 degrees-of-freedom, the program must be able to solve a set of 1000 simultaneous equations. Even though a model with n degrees-of-freedom will yield n modes, most of these modes are well outside of the frequency range of interest. Therefore, during the eigenvalue solution process, normally only the m modes which cover the frequency range of interest are extracted. Still, the solution times can be long because the basic problem size is still $n \times n$.

With a modal model, the dynamics are described by m modes and the problem size which must be handled is reduced

to $m \times m$. The benefits to this concise model are that it can be easily implemented on a much smaller computer than is normally required for FEA, and the solution times are much faster.

Once we have a modal dynamic model of the structure we have an opportunity to use it for two important applications, both of which are fundamental in helping us solve problems.

Structural Dynamics Modification

First, it is possible to use a computer-based modeling program such as the Structural Dynamics Modification (SDM)* system to help answer the so-called "what if..." question.^{2,3}

With modeling programs like SDM, a user can determine the effects of adding scalar springs and dampers, and point masses to a structure. For example, what if a stiffener is added between points A and B. How will the modified structure behave dynamically? *An important advantage of SDM is that it uses modal data to characterize the dynamics of the unmodified structure, and this data can be obtained either from experimental testing, or from an analytical model.* SDM allows the user to specify changes to the mass, stiffness or damping properties of a structure, and it determines the resultant dynamic (modal) properties of the modified structure. Alternatively, the user can also specify changes to the modal frequency and damping properties of the structure, and SDM will determine the amount of mass, damping or stiffness modification which is necessary in order to cause the specified changes in its dynamics.

Structural modification programs can also be used to analytically couple together and determine the overall dynamics of two or more substructures. This capability makes it much easier to measure or model the dynamics of large complex structures which can be conveniently subdivided into an assemblage of substructures. It is also more convenient to study the effects of alternative substructure designs upon the dynamics of the overall structure, and to study inter-connections between substructures. This substructuring capability can also be used to study the effects of adding tuned mass-spring-damper vibration absorbers to structures.

It should be clear that programs like SDM are of considerable value to the experimentalist because they allow him to try numerous solutions (mass, stiffness or damping changes) quickly, accurately, and easily by doing the modifications on a computer instead of with actual hardware. A typical SDM solution may require 30 seconds, whereas another complete experimental analysis might require anywhere from several hours to several days! Figure 7 illustrates this concept.

* Structural Dynamics Modification and SDM are registered trademarks of Structural Measurement Systems, San Jose, CA.

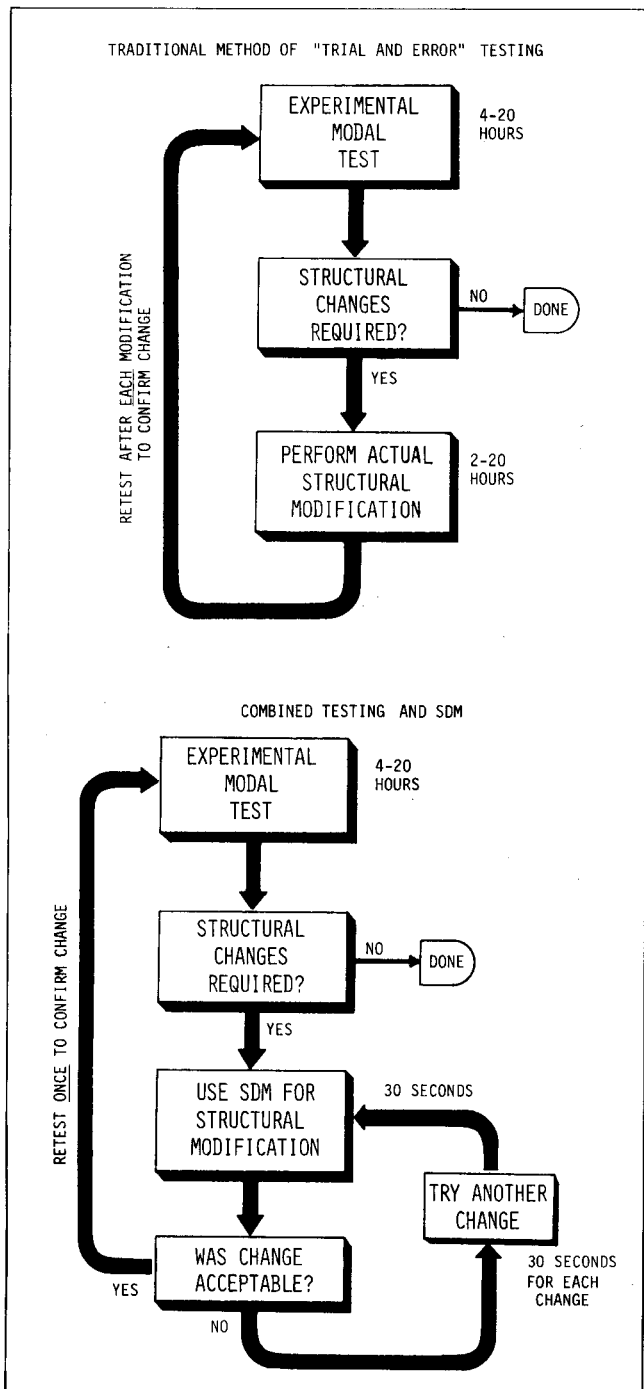

Figure 7. Procedures for troubleshooting noise and vibration problems.

The analytical people are faced with a completely different but similar set of problems. Popular IEM computer codes such as NASTRAN, ANSYS, STARDYNE, SAP, and ASAS, to name only a few, are generally used only by skilled dynamicists. All of these codes require a large mainframe or super-mini computer and, in general, may be expensive and time-consuming to run. As an example, one automotive company that uses NASTRAN and has FEM models of about 2000 degrees-of-freedom (normally considered to be an average size model) reports that a typical run may cost anywhere from \$400 to \$1,000, and requires up to a day in

order to finally obtain printed and plotted results. Obviously, with this kind of long turnaround time, it is impossible to try many different types of structural modifications.

SDM can be of real value to people doing FEM analysis because it can allow an analyst to try many different potential structural modifications (mass, stiffness or damping) in just a few minutes. Then, when he sees a result from SDM that is promising, he can let the full FEM model run that particular case. In this way, he can use the FEM code more efficiently, and has thus made it much easier to find optimum solutions to structural behavior problems. Figure 8 summarizes this idea.

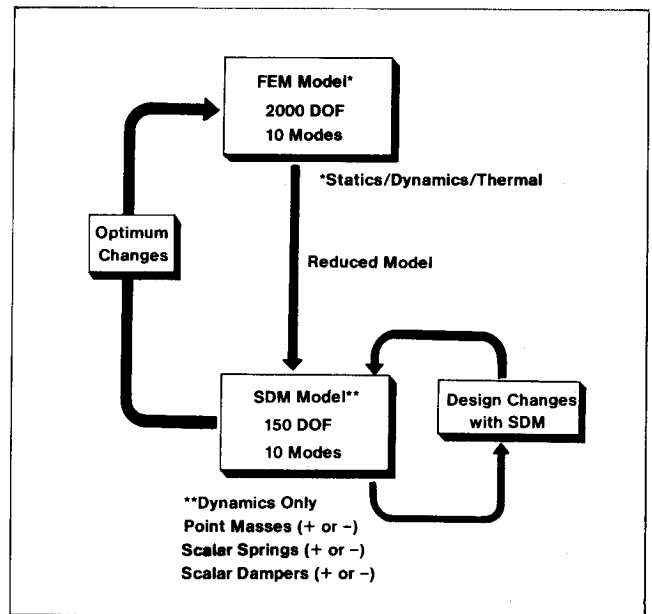

Figure 8. Relationships between FEM and SDM models.

Forced Response Simulation

Forced Response Simulation (FRS) is a second important use of the modal model. With FRS, a user can actually examine the effects of "real world" forces on the dynamic response of the structure. It is an easy exercise to specify the forcing function at an arbitrary point or points on the structure (where there is modal data, i.e. a DOF) and use FRS to observe the displacement, velocity or acceleration response caused by that combination of excitation forces at any DOF in the model.

These input forces may be specified as time domain waveforms, linear frequency spectrums or power spectrums, and may take any form, be it random, sinusoidal, transient, or a combination of the above.

Bringing It All Together

Unfortunately, organizations which have recognized the value of being able to effectively predict a structure's dynamic behavior, have also found that the costs for both the experimental and the analytical approach have been large. As a result, only the larger organizations were able to provide their design engineers with the modern experimental and analytical tools which were necessary.

However, in just the last few years, four major technological breakthroughs have occurred which promise to bring a new

host of experimental and analytical capabilities to the average design engineer, and at a cost that is affordable by the vast majority of companies.

Interestingly enough, two of these major technological innovations are in hardware and two are in software. It is the author's feeling that this trend will continue as customers demand tools which lead them closer and closer to solutions of their problems, because the tools required will be a combination of sophisticated measurement and computational hardware combined with easy-to-use application software.

The four innovations were:

1. Manufacturers of digital signal analyzers such as Wavetek-Rockland; Spectral Dynamics, Scientific Atlanta; Hewlett-Packard; Zonic; Nicolet; GenRad and others introduced new models of dual-channel FFT signal analyzers which were capable of making high-quality frequency response measurements at a much lower cost than had ever been possible before. Frequency response measurements are the key to experimental modal analysis.

2. Hewlett-Packard, Tektronix and others introduced extremely powerful desktop computers. These machines brought the power of a minicomputer directly to an engineer's desk, again at only a fraction of the cost of a traditional minicomputer. Equally important was the fact that because they were so easy to use compared to a minicomputer many more engineers started to use them and soon found them to be an indispensable general engineering tool.
3. In 1979, Structural Measurement Systems of San Jose, CA introduced the first structural modification software package that was specifically designed to operate on a desktop computer and use experimental modal analysis data as its basis. This software allowed engineers to use measured modal data to formulate a dynamic model of their structure and then to quickly investigate the effects of possible mass, stiffness and/or damping changes on the dynamics of the new or "modified" structure. The SMS package is known as Structural Dynamics Modification (SDM), and has been used in numerous applications worldwide.

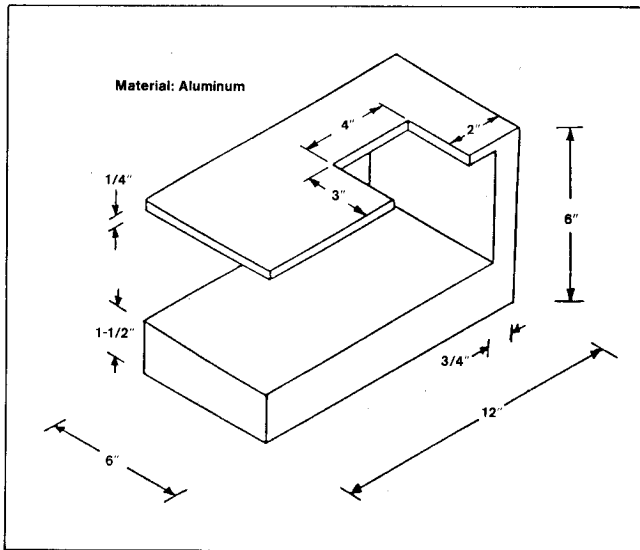

Figure 9. SDM/FESDEC test structure.

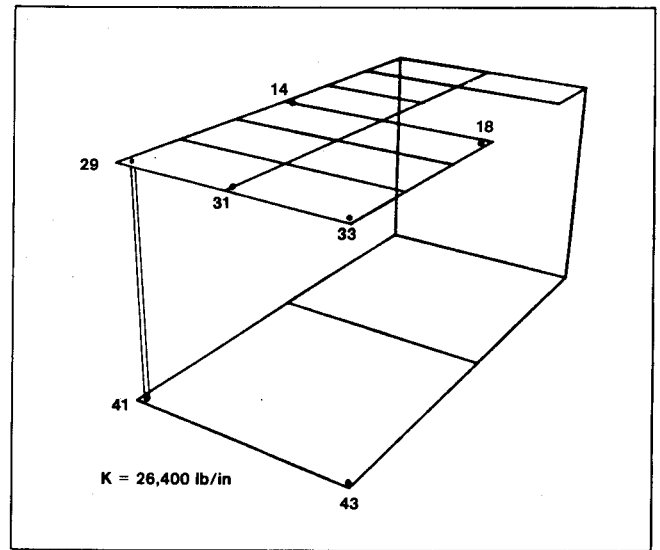

Figure 11. Modified test structure.

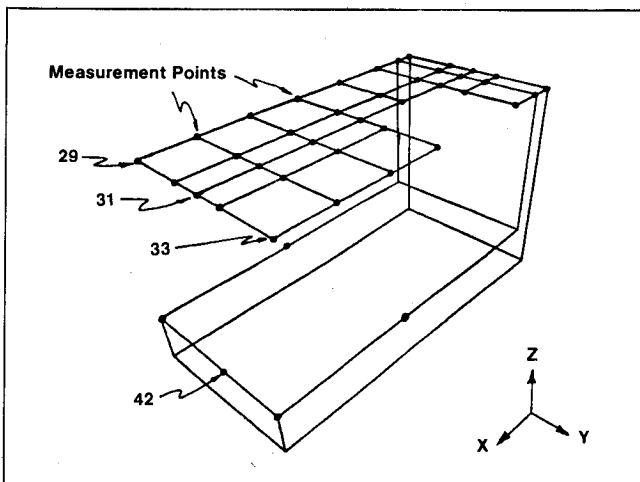

Figure 10. Unmodified test structure.

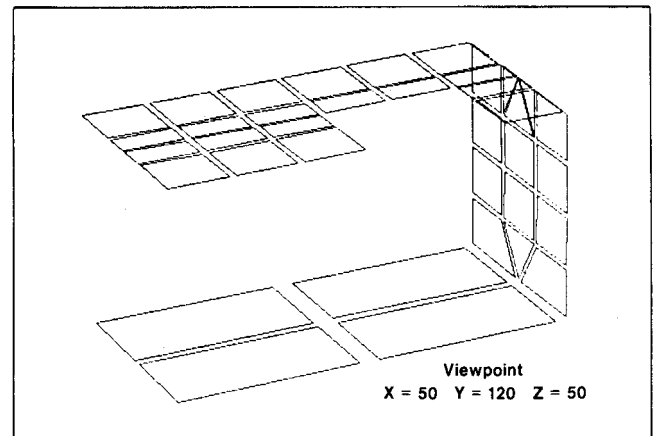

Figure 12. FEM mesh grid.

4. In 1980, H.G. Engineering of Toronto, Canada and ECS Ltd. in the United Kingdom introduced the first commercially available finite element analysis program for use on desktop computers.⁴ This program, called "FESDEC," gave engineers many of the same facilities available in large finite element systems but in a powerful and inexpensive desktop computer. FESDEC offered the designer linear elastic-static analysis, linear dynamic modal analysis, and linear heat conduction solutions. It thus brought a sophisticated analytical design tool within reach of a great number of engineers, primarily because it overcame the two major objections to using large scale FEM codes or service bureaus; namely difficulty of use and cost.

With these achievements, users now have access to a full complement of experimental and analytical tools, but at a fraction of the historical cost. For example, it is now possible to use a wide variety of dual-channel FFT analyzers to make the basic frequency response measurements and then utilize a desktop computer to perform the actual modal analysis. This same desktop computer will also run the FESDEC and SDM programs. *These programs have been designed such that they can share a common modal data base.* As a result, SDM can be used on the analytical data as well as the experimental data.

An Example Combining Analysis and Test

In the following example, a comparison has been made between test data acquired from the modal test of some hardware, using a dual channel FFT analyzer and numerical models produced from the SDM program and the FESDEC Finite Element program, both of which run on the HP 9800 series desk top computers. Because the tests, analyses, and structural modifications were carried out at different times and usually in different locations by different people, *the comparisons yield some insight into the synergy that can develop between test and analysis.* This is of particular interest because *the techniques employed in either test or analysis are not infallible and mistakes can often be picked up through a comparison.* Another obvious advantage is that of learning what analytical assumptions are important in building a FE

model for a particular component. This 'calibration' of the numerical model can be very useful in producing a good analysis of a future design of similar shape.

Figure 9 shows the dimensions of a "U" shaped bracket which is fabricated out of three aluminum plates bolted together at their adjoining edges. The top plate has an irregular cutout which effectively destroys the symmetry of the structure.

The structure was tested using an impact technique and the results collected and analyzed using the FFT analyzer for frequencies up to 500 Hz. The layout of the test points is shown in Figure 10. Measurements were collected at 43 different points, resulting in a total of 129 degrees-of-freedom. The response accelerometer was placed at the outside corner of the top plate (33). The structure was impacted in most cases normal to the surface but where a point lay on the edge it was also struck parallel to the plane of the plate. A second test was conducted with a piece of brass rod connecting one corner of the top plate to the base plate as shown in Figure 11. In all cases the structure was tested while resting on a block of foam rubber to simulate the free-free condition.

The finite element analysis was conducted using a three-dimensional plate model with the mesh shown in Figure 12. A lumped mass representation of the structure was calculated by the program. The model contained 56 nodes and 319 Degrees-Of-Freedom (DOF), each node of the model having 6 DOF.

The first analysis was conducted using sufficient constraints at the base to remove the six overall rigid body modes. It was argued that the base was very heavy compared to the two other plates and hence this would be a fair assumption. The second analysis was run including a grounded spring at the corner of the top plate to represent the tie rod used in the test. Finally a run was made with rigid body motion permitted in the vertical plane.

Structural Dynamics Modification (SDM) was applied to 5 modes of the original experimental test data and to the modal data obtained from the finite element model. In each case a spring equal to the stiffness of the rod was added between the top and bottom plate.

Table 2. Comparison of test results.

Mode No.	Modal Test Results (Frequencies in Hz) and Times Required for Test or Calculation						
	1	2	3	4	5	6	7
	Test Results from the Unmodified Structure	Test Results from the Modified Structure	SDM Predictions for the Modified Structure (using data from #1)	FEM Predictions for the Unmodified Structure (fixed-free condition)	FEM Predictions for the Unmodified Structure (free-free condition)	FEM Predictions for the Modified Structure	SDM Predictions for the Modified Structure (using FEM data from #4)
1	45.7	103.1	104.7	42.6	45.2	98.0	101.0
2	169.4	256.1	257.1	165.9	167.7	243.0	243.0
3	262.2	284.5	284.3	242.7	275.5	269.0	271.0
4	289.1	355.1	355.5	284.3	293.1	347.0	347.0
5	365.2	Not measured	Not valid above 500 Hz	350.9	396.1	515.0	Not valid above 500 Hz
	4 Hours	4 Hours	30 Seconds	3 Hours	3 Hours	3 Hours	30 Seconds

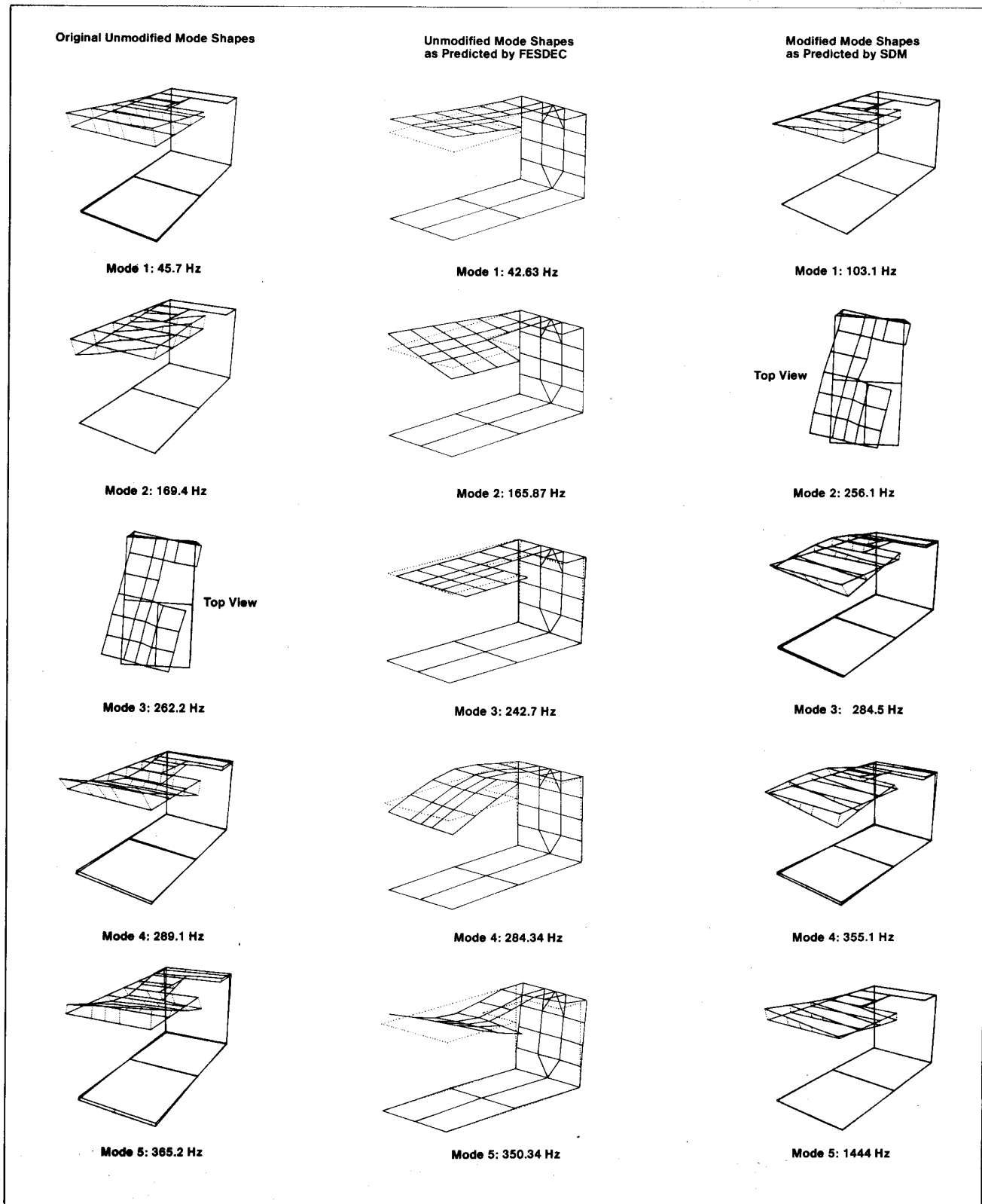

Figure 13. Comparison of mode shapes.

In this example, a simple finite element model was built to represent the structure tested and was run on a desktop computer with only 1.2 megabytes of disc storage using the FESDEC program. Modifications made by the SDM technique were all executed in a matter of minutes using the SMS

package running on the same desktop computer. It is believed that the example illustrates the sort of procedures that could have been followed by design or test engineers to quickly evaluate the dynamic characteristics of the structures considered.

With Finite element modeling, modal testing and structural dynamics modification, the engineer has a range of tools to take him from preliminary design to prototype testing and all in the convenient working environment provided by the modern desktop computer.

In Figure 13, the modes of the unmodified structure are compared to the modes of the modified structure as predicted by SDM (from the original test data) and by FESDEC. Numerical values are tabulated in Table 2.

As can be seen, the SDM predicted and FESDEC predicted mode shapes and frequencies compare quite well. In order to check the accuracy of the prediction, the structure was actually modified and retested to determine the true effect of the rod. As can be seen in Table 2, the SDM predicted results are quite accurate. A complete comparison is documented in full in SAE Paper No. 801125 entitled "Applications of Structural Dynamics Modification" by Herbert and Kientzy.⁵

As a postscript to the finite element analysis it is interesting to note the process by which the final model evolved. The first results shown in the table were not, in fact, the first obtained. An earlier model was built with one less row of elements in the back plate and this predicted all but the third mode which was missed completely. It can be seen by examining the mode shape that this involves almost pure twisting of the back plate. When the model was refined and the modes were complete but low, a number of ideas were offered to explain the difference. It was argued that because the base plate was thick compared to the overall dimensions, our model had overestimated the flexibility of the back plate by using a length that went from the center of the top plate to the center of the base plate. As it transpired, the problem had more to do with the fact that the fixed-free rather than the free-free modes had been extracted.

Finally, it is worthwhile to discuss the times required to obtain the results in Table 2. Column #1, the first modal test on the original unmodified structure required about 4 hours. This test was done using the impact method at 43 different points. A total of 73 measurements (X, Y, and Z directions) were made; then, using constraint condition, the final problem size was 129 DOFs.

Column #2, the modal test of the modified structure, again required about 4 hours to complete. Column #3 is the modified results as predicted by SDM, using the data from Column #1. The time required for Column #3 was about 30 seconds.

Columns #4 and #5 are the finite element results of the unmodified structure for two different boundary condition cases. Each was a complete dynamic analysis and each required about 3 hours to complete.

Column #6 is another finite element run of the original structure, but with the rod element added. This solution also required about 3 hours to obtain using the HP 9845 Desktop Computer.

Finally, Column #7 is the SDM result for the modified structure, using the FEM data from Column #4 as the input. As with other SDM runs, this required about 30 seconds.

It is interesting to note that the results shown in Columns #6 and #7 agree quite well with the actual test results as shown in Column #2, even though the input data came from Column #4, the least accurate of the FEM results. It is entirely reasonable

to expect even more accurate results if the better FEM data from Column #5 had been used.

In comparing the results we note the following:

1. *The SDM method accurately represents the change in frequencies measured in the test when the stiffening rod was added to the model. Due to the limitations in the original data it is unable to predict the fifth mode that is now beyond 500 Hz.*
2. *The original finite element analysis underestimates the frequencies of the model although the mode shapes seem identical. This is unexpected as the numerical analysis would normally predict too stiff a result and hence a higher frequency.*
3. *The modified finite element model correctly predicts the changes in mode shape and frequency but once again underestimates the results. It is however able to demonstrate the new fifth mode just above 500 Hz.*
4. *The SDM modified finite element data agrees well with the changed finite element model but one again misses the fifth mode.*
5. *It is seen finally by running the free-free modes of the structure that this does in fact make some difference to all the modes and that, in particular, the first mode is very close in frequency to the test structure. Generally as was previously anticipated, the frequencies are higher than the tested data.*

References

1. Richardson, M. and Ramsey, K., "Integration of Dynamic Testing into the Product Design Cycle," *Sound and Vibration*, November 1981.
2. Formenti, D. and Welaratna, S., "Structural Dynamics Modification - An Extension to Modal Analysis," SAE Paper No. 811043, October 1980.
3. Structural Measurement Systems, "An Introduction to the Structural Dynamics Modification System," Technical Note No. 1, February 1980.
4. Firmin, A. and Jones, R. T., "FESDEC - A New Finite Element System for Desktop Computers," ASME Paper, August 1980.
5. Herbert, M. and Kientzy, D., "Applications of Structural Dynamics Modification," SAE Paper No. 801125, October 1980.

Based on a paper presented at the 1st International Modal Analysis Conference sponsored by Union College, Orlando, FL, Nov. 1982.